



SINGLE-DECK



LENGTHs : GALVANIZED

DOUBLE-DECK



LENGTH

LENGTHs : GALVANIZED

SINGLE-DECK

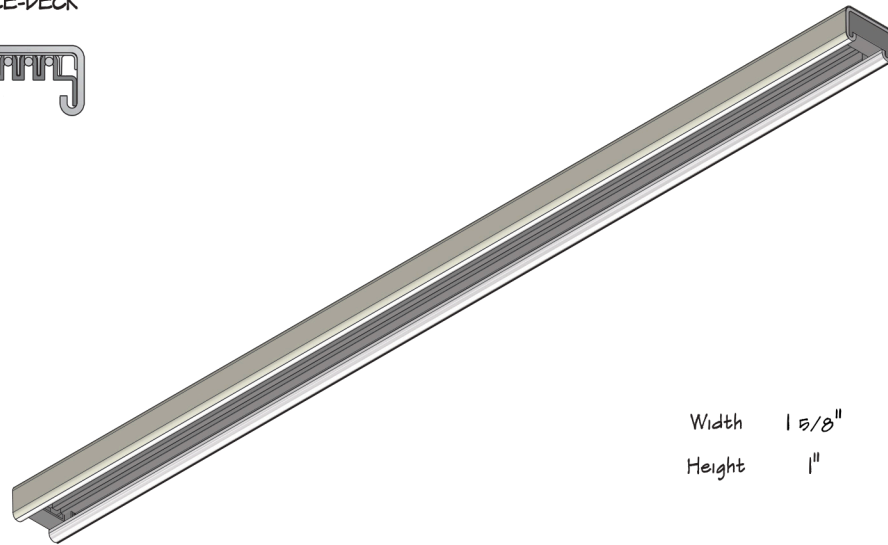
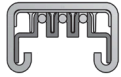

Width 1 5/8"
Height 1"

DOUBLE-DECK

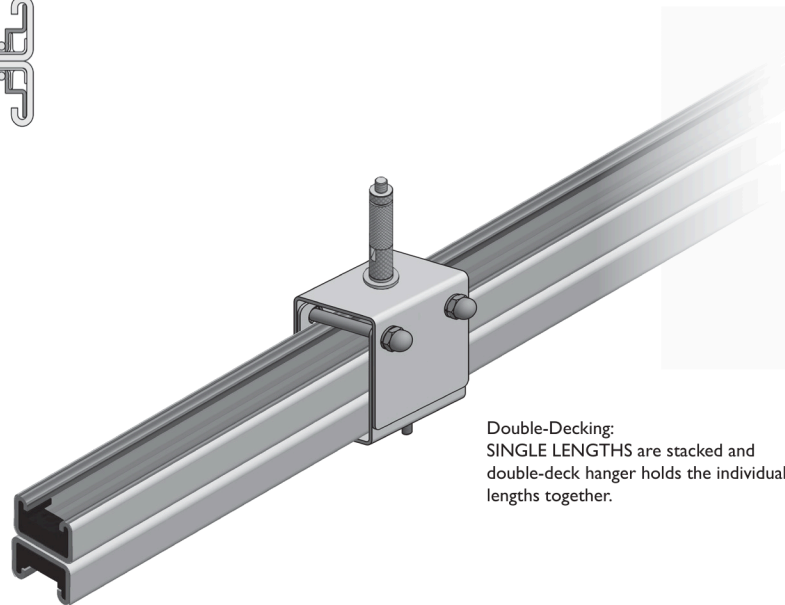
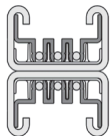

Double-Decking:
SINGLE LENGTHS are stacked and double-deck hanger holds the individual lengths together.

USA TrackBusway™				
SINGLE / DOUBLE-DECK (two single lengths)				
			(L)	(F)
20 AMP	up to 600V MAX.	M20-3-40-600-(L)-(F)-B	2.5' 5' 10' XX' (CUSTOM LENGTH)	G SC W B
40 AMP	up to 600V MAX.	M40-3-80-600-(L)-(F)-B	2.5' 5' 10' XX' (CUSTOM LENGTH)	G SC W B
EMPTY	NON-POWERED	M00-(L)-(F)-B	2.5' 5' 10' XX' (CUSTOM LENGTH)	G SC W B

Finish - G=Galvanized SC=Sleeved Copper W=White B=Black

The double-deck is a PREWIRED, 1-5/8" wide x 2" tall, 12 Ga. steel, 4-Pole busway designed for 3-phase power distribution. It consists of two individual 1" tall lengths stacked vertically, forming a compact double-height assembly.

As shown in the wiring diagram below, two phases are distributed on the lower deck, while the third phase is tapped via the top deck. This configuration delivers a streamlined and scalable solution for 3-phase layouts across rows and grids.

Lengths are available in up to 40A and offered in galvanized, sleeved copper, white, or black finishes, with standard lengths of 2.5', 5', 10', and custom sizes.

Each piece features built-in endblocks — no end caps needed — and feeds can be added even after a joiner sleeve, providing maximum flexibility in power-density for your space.

